

Spring return actuator with emergency function for adjusting air dampers in ventilation and air conditioning systems in buildings

- For air dampers up to approx. 6 m²
- Torque 30 Nm
- Nominal voltage AC/DC 24 V
- Control: Open-close
- Two integrated auxiliary switches



Technical data

Electrical data	Nominal voltage	AC 24 V, 50/60 Hz / DC 24 V	
	Nominal voltage range	AC 19.2 ... 28.8 V / DC 21.6 ... 28.8 V	
	Power consumption	In operation	9.5 W @ nominal torque
		At rest	4.5 W
		For wire sizing	16 VA
	Auxiliary switch	2 x SPDT, 1 mA ... 3 (0.5) A, AC 250 V ☐ (1 x fix 10% / 1 x adjustable 10 ... 90%)	
Connection	Motor	Cable 1 m, 2 x 0.75 mm ²	
	Auxiliary switch	Cable 1 m, 6 x 0.75 mm ²	
Functional data	Torque	Motor	Min. 30 Nm @ nominal voltage
		Spring return	Min. 30 Nm
	Direction of rotation	Can be selected by mounting L / R	
	Manual override	With hand crank and interlocking switch	
	Angle of rotation	Max. 95°↔, can be limited with adjustable mechanical end stop	
	Running time	Motor	≤75 s (0 ... 30 Nm)
		Spring return	≤20 s @ -20 ... 50°C / max. 60 s @ -30°C
	Sound power level	Motor	≤55 dB (A)
		Spring return	≤71 dB (A)
	Service life	Min. 60,000 emergency positions	
Position indication	Mechanical		
Safety	Protection class	III Extra low voltage UL Class 2 Supply	
	Degree of protection	IP54	
		NEMA2, UL Enclosure Type 2	
	EMC	CE according to 2004/108/EC	
	Low-voltage directive	CE according to 2006/95/EC	
	Certification	Certified to IEC/EN 60730-1 and IEC/EN 60730-2-14 cULus according to UL 60730-1A and UL 60730-2-14 and CAN/CSA E60730-1:02	
	Mode of operation	Type 1.AA.B	
	Rated impulse voltage	Actuator	0.8 kV
		Auxiliary switch	2.5 kV
	Control pollution degree	3	
Ambient temperature	-30 ... +50°C		
Non-operating temperature	-40 ... +80°C		
Ambient humidity	95% r.h., non-condensating		
Maintenance	Maintenance-free		
Dimensions / Weight	Dimensions	See «Dimensions» on page 3	
	Weight	Approx. 4.4 kg	

Safety notes



- The actuator is not allowed to be used outside the specified field of application, especially in aircraft or in any other airborne means of transport.
- It may only be installed by suitably trained personnel. Any legal regulations or regulations issued by authorities must be observed during assembly.
- The device may only be opened at the manufacturer's site. It does not contain any parts that can be replaced or repaired by the user.
- The cables must not be removed from the device.
- When calculating the required torque, the specifications supplied by the damper manufacturers (cross-section, design, installation site), and the air flow conditions must be observed.
- The integrated switches of this actuator have to be connected either to Power supply voltage or safety extra low voltage. The combination Power supply voltage / safety extra low voltage is not allowed.
- The device contains electrical and electronic components and is not allowed to be disposed of as household refuse. All locally valid regulations and requirements must be observed.

Product features

Mode of operation	The actuator moves the damper to the operating position at the same time as tensioning the return spring. The damper is turned back to the safety position by spring force if the supply voltage is interrupted.
Simple direct mounting	Simple direct mounting on the damper spindle with a universal spindle clamp, supplied with an anti-rotation strap to prevent the actuator from rotating.
Spindle stabiliser	The spindle clamp of the spring-return actuator is equipped ex-works with a spindle stabiliser for stabilising the combination of damper, damper spindle and actuator. This is comprised of two plastic support rings and, depending on the installation situation and the spindle diameter, must be left in place or partially or completely removed. Long spindle installation: <ul style="list-style-type: none"> • The use of the spindle stabiliser is necessary with long spindle installation with a spindle diameter of 12 to 20 mm. • The use of the spindle stabiliser is not necessary with long spindle installation with a spindle diameter of 21 to 26.7 mm, and it can be removed. Short axis installation: <ul style="list-style-type: none"> • The necessity of the spindle stabiliser does not apply with short spindle installation; it can be removed or – if the length of the spindle permits it – left in the spindle clamp. For additional information, see the Installation instructions.
Manual override	Manual operation of the damper with the hand crank, locking in any position with the interlocking switch. Unlocking is manual or automatic by applying the operating voltage.
Adjustable angle of rotation	Adjustable angle of rotation with mechanical end stop.
High operational reliability	The actuator is overload-proof, requires no limit switches and automatically stops when the end stop is reached.
Flexible signalization	The actuator has one auxiliary switch with a fixed setting and one adjustable auxiliary switch. They permit a 10% or 10 ... 90% angle of rotation to be signalled.

Important

The spindle stabiliser must nonetheless be used when the universal mounting bracket is installed on the opposite side of the spindle clamp and with a spindle diameter <20 mm.



Electrical installation

Wiring diagram

Notes

- Connect via safety isolation transformer.
- Parallel connection of other actuators possible. Note the performance data.

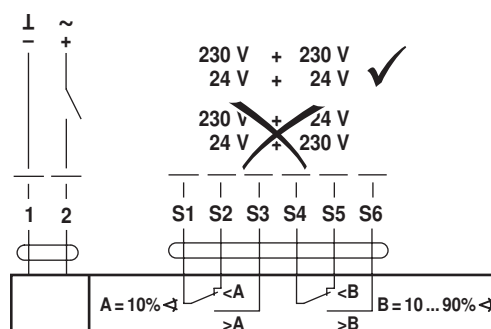
**Cable colours:**

- 1 = black
- 2 = red
- S1 = violet
- S2 = red
- S3 = white
- S4 = orange
- S5 = pink
- S6 = grey

Accessories

Mechanical accessories

Description

- Position indicator IND-EFB
- Clamp K9-2
- Crank arm KH-EFB
- Crank arm adaptor kit ZG-EFB

Dimensions [mm]

Dimensional drawings

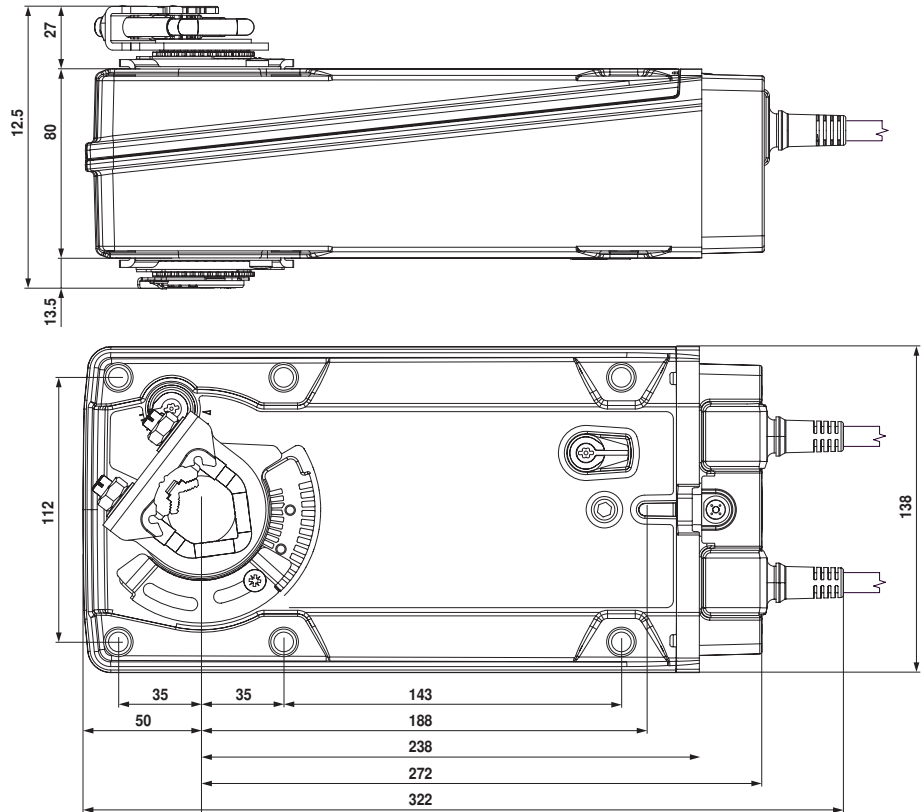

Damper spindle	Length			
	≥117	12 ... 26,7	>12	<25,2
	≥20	12 ... 26,7	>12	<25,2

