

DESCRIPTION

Gas interception automatic normally closed solenoid valves that open when the coil is powered and close when there is no tension.

These solenoid valves can be controlled by pressure switch, thermostat, etc.

They can be equipped with CPI Switch.

INSTALLATION

The solenoid valve is in conformity with the Directive 2014/34/EU as device of group II, category 3G and as device of group II, category 3D; for this reason it is suitable to be installed in the zones 2 and 22 as classified in the attachment I to the Directive 99/92/EC. The solenoid valve is not suitable to be used in zones 1 and 21 and, all the more so, in zones 0 and 20 as classified in the already said Directive 99/92/EC.

To determine the qualification and the extension of the dangerous zones, see the norm CEI EN 60079-10-1.

The device, if installed and serviced respecting all the conditions and the technical instructions of this document, is not source of specific dangers: in particular, during the normal working, is not forecast, by the solenoid valve, the emission in the atmosphere of inflammable substance in way to cause an explosive atmosphere.

WARNING: all installation/wiring/maintenance work must be carried out by skilled staff.

- The gas supply must be shut off before installation.
- Check that the line pressure **DOES NOT EXCEED** the maximum pressure stated on the product label.
- They must be installed with the arrow (on the body **(4)** of the device) facing towards the user appliance. They will function equally effectively if installed vertical. They must not be installed upside down (with the coil **(11)** underneath).
- During installation take care not to allow debris or scraps of metal to enter the device.
- If the device is threaded check that the pipeline thread is not too long; overlong threads may damage the body **(4)** of the device when screwed into place. Do not use the coil **(11)** for leverage when screwing into position; use the appropriate tool. Assemble pipe and fittings which are consistent with solenoid valve connection threads.

- If the device is flanged check that the inlet and outlet counterflanges are perfectly aligned to avoid unnecessary mechanical stresses on the body of the device. Also calculate the space needed to fit the seal. If the gap left after the seal is fitted is too wide, do not try to close it by over-tightening the device's bolts.
- We always suggest to mount a compensation joint (VDJ).
- Always check that the system is gas-tight after installation.

ELECTRICAL CONNECTIONS

Before making electrical connections, check that the mains voltage is the same as the power supply voltage stated on the product label.

- Disconnect the power supply before wiring.
- Wire the connector **(1)** with H05SS-K 3X1 mm² cable outside Ø from 8.3 a 9.5 mm, taking care to ensure that the device has IP65 protection.
- Connect the power supply to terminals 1 and 2 and the ground wire to terminal \perp .

• **IMPORTANT:** with tension 24 Vdc observe the polarity. The coil **(11)** is also suitable for permanent power supply. In case of continuous duty, it is absolutely normal for the coil to heat up. The coil **(11)** should not be touched with bare hands after it has been continuously powered for more than 20 minutes. Before maintenance work, wait the coil temperature decreases or use suitable protective equipment.

For any problems or information concerning installation/wiring/maintenance operations, see address and telephone numbers on the back page.

TECHNICAL DATA

- Use : not aggressive gases of the three families (dry gases)
- Environment temperature : -20 ÷ +60 °C
- Max. superficial temperature * : 85 °C
- Power supply voltage (see table) : 24 Vdc - 24 V/50 Hz - 110 V/50-60 Hz - 230 V/50-60 Hz
- Power supply voltage tolerance : -15% ... +10%
- Cycles/hour : see table
- Power absorption : see table
- Max. working pressure : 360 mbar
- Closing time : < 1 s
- Degree of protection : IP65
- Class : A
- Group : 2
- Threaded connections Rp : (DN 32 ÷ DN 50) according to EN 10226
- Flanged connections PN 16 : (DN 65 ÷ DN 150) according to ISO 7005
- Threaded connections NPT or flanged ANSI : on request

* The maximum superficial temperature is calculated powering the solenoid valve at the nominal tension increased of 10% and at the maximum environmental temperature.

SERVICING

In all cases, before performing any internal checks make sure that:

1. the power supply to the device is disconnected
2. there is no pressurised gas inside the device (see fig. 1, 2, 3, and 4) unscrew the screw/nut **(12)** and remove the coil **(11)**. Unscrew the fixing screws **(9)** and, with care, take the cover **(10)** off the body **(4)** of the valve, then control the obturator **(5)** and if it is necessary change the rubber made seal component **(6)**. Then clean or blow the filter **(8)** or change it if necessary. Then assemble doing backward the same operation.

Coils and connectors									
Valve code	Connections	Tension	Coil + connector code	Coil stamping	Connector type	Energy Saving	Powwer absorption	Max Cycles/hour	Min OFF time (s)
GCA 332/360	Rp DN 32	24 Vdc	BO-1010	BO-1010 24 Vdc DN 32 - 40 - 50	Normale - Normal	NO	47 VA	120	2
GCA 340/360	Rp DN 40								
GCA 350/360	Rp DN 50								
GCA 432/360	Rp DN 32	24 V/50 Hz	BO-1015	BO-1015 24 Vac DN 32 - 40 - 50	Energy Saving 24 Vac	YES	47 VA Energysaving 13 VA	120	2
GCA 440/360	Rp DN 40								
GCA 450/360	Rp DN 50								
GCA 632/360	Rp DN 32	110 V/50-60 Hz	BO-1020	BO-1020 110 Vac DN 32 - 40 - 50	Energy Saving 110 Vac - 230 Vac	YES	46 VA Energysaving 13 VA	120	2
GCA 640/360	Rp DN 40								
GCA 650/360	Rp DN 50								
GCA 832/360	Rp DN 32	230 V/50-60 Hz	BO-1030	BO-1030 230 Vac DN 32 - 40 - 50	Energy Saving 110 Vac - 230 Vac	YES	55 VA Energysaving 16 VA	120	2
GCA 840/360	Rp DN 40								
GCA 850/360	Rp DN 50								
GCA 365	DN 65	24 Vdc	B13105	BO-1110 24 Vdc DN 65 - 80	Energy Saving 24 Vdc	YES	185 VA Energysaving 50 VA	120	2
GCA 380	DN 80								
GCA 465	DN 65	24 V/50 Hz	B13055	BO-1115 24 Vac DN 65 - 80	Energy Saving 24 Vac	YES	185 VA Energysaving 50 VA	120	2
GCA 480	DN 80								
GCA 665	DN 65	110 V/50-60 Hz	B13092	BO-1120 110 Vac DN 65 - 80	Energy Saving 110 Vac	YES	260 VA Energysaving 70 VA	120	2
GCA 680	DN 80								
GCA 865	DN 65	230 V/50-60 Hz	B13054	BO-1130 230 Vac DN 65 - 80	Energy Saving 230 Vac	YES	290 VA Energysaving 75 VA	120	2
GCA 880	DN 80								
GCA 3100	DN 100	24 Vdc	B13106	BO-1210 24 Vdc DN 100	Energy Saving 24 Vdc	YES	130 VA Energysaving 40 VA	120	2
GCA 4100	DN 100	24 V/50 Hz	B13057	BO-1215 24 Vac DN 100	Energy Saving 24 Vac	YES	120 VA Energysaving 35 VA	120	2
GCA 6100	DN 100	110 V/50-60 Hz	B13093	BO-1220 110 Vac DN 100	Energy Saving 110 Vac	YES	270 VA Energysaving 70 VA	120	2
GCA 8100	DN 100	230 V/50-60 Hz	B13056	BO-1230 110 Vac DN 100	Energy Saving 230 Vac	YES	270 VA Energysaving 70 VA	120	2
GCA 3125	DN 125	24 Vdc	B13105	BO-2110 24 Vdc DN 125 - 150	Energy Saving 24 Vdc	YES	130 VA Energysaving 40 VA	35	2
GCA 3150	DN 150								
GCA 4125	DN 125	24 V/50 Hz	B13055	BO-2115 24 Vac DN 125 - 150	Energy Saving 24 Vac	YES	130 VA Energysaving 40 VA	35	2
GCA 4150	DN 150								
GCA 6125	DN 125	110 V/50-60 Hz	B13092	BO-2120 110 Vac DN 125 - 150	Energy Saving 110 Vac	YES	270 VA Energysaving 70 VA	35	2
GCA 6150	DN 150								
GCA 8125	DN 125	230 V/50-60 Hz	B13054	BO-2130 230 Vac DN 125 - 150	Energy Saving 230 Vac	YES	270 VA Energysaving 70 VA	35	2
GCA 8150	DN 150								

LOAD LOSS DIAGRAM

Diagram calculated with P1 = 50 mbar

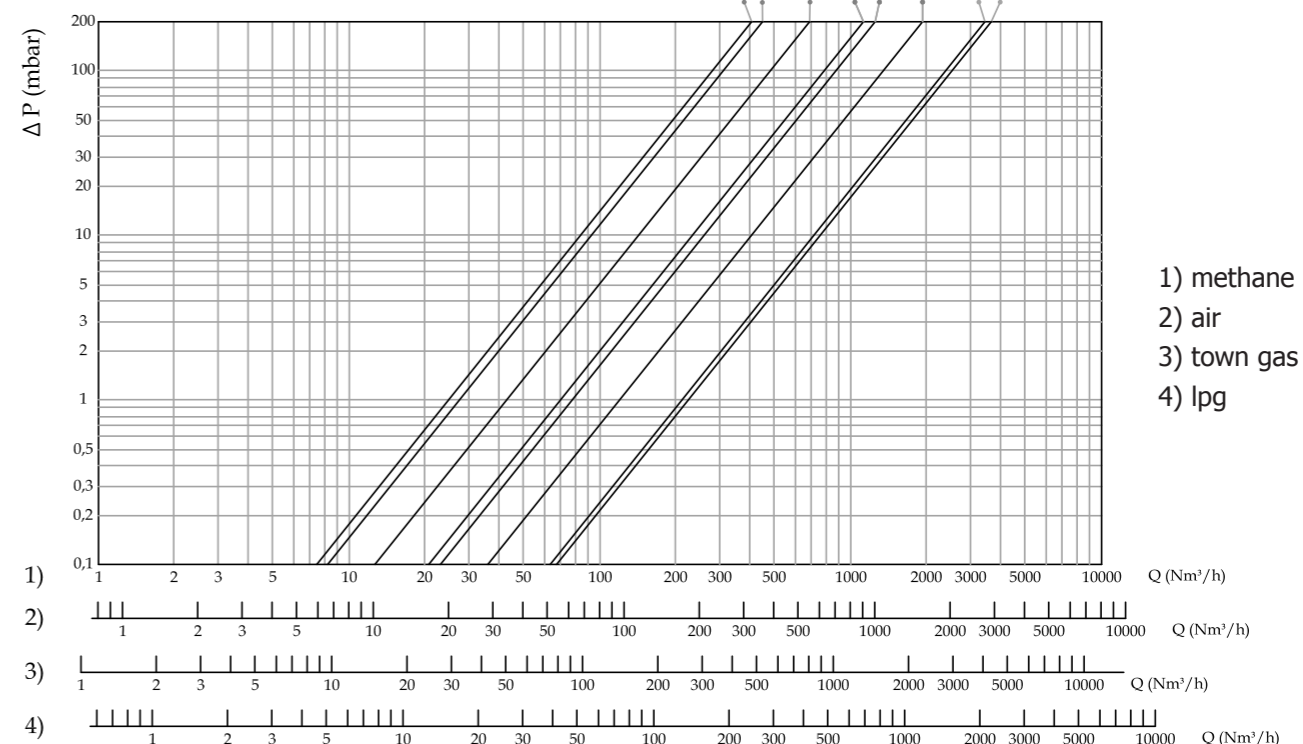

⚠ The above-said operations must be carried out only by qualified technicians.

fig. 1 - Abb. 1
GCA/360 DN Rp 32 - Rp DN 40 P.max 360 mbar

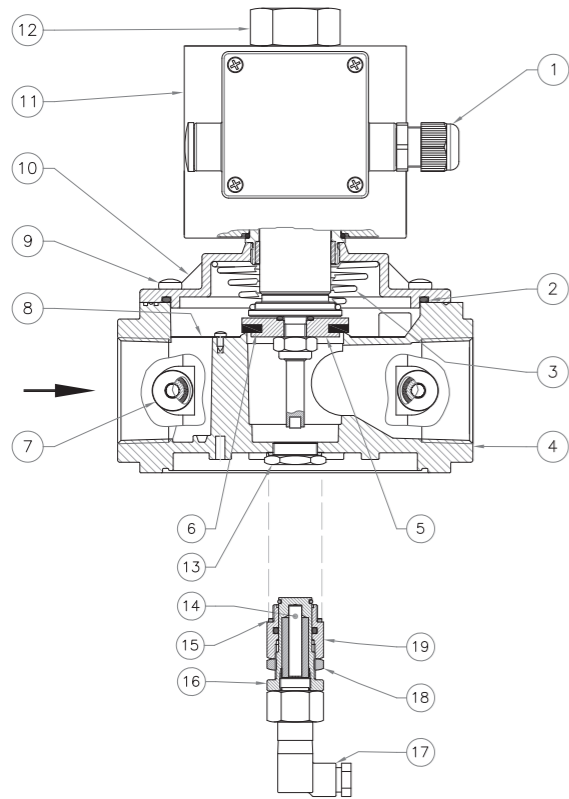

fig. 2 - Abb. 2
GCA/360 Rp DN 50 P.max 360 mbar

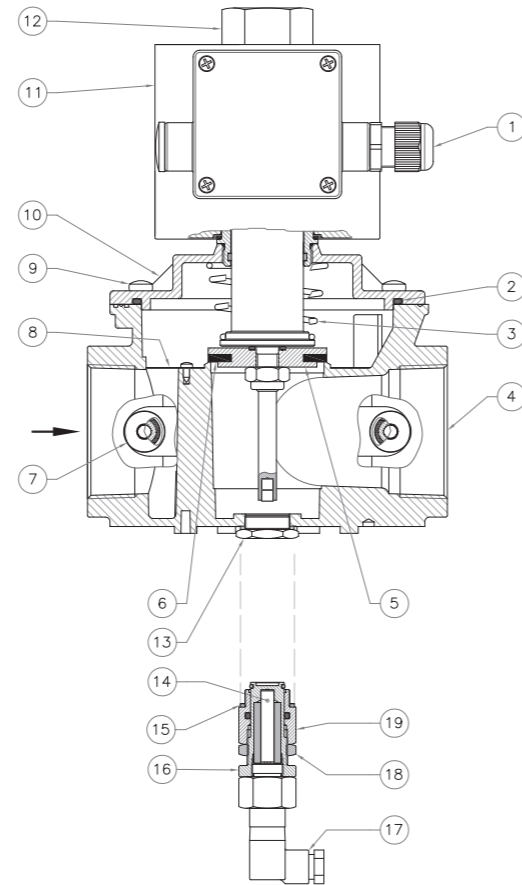

fig. 3 - Abb. 3
GCA DN 65 - DN 80 - DN 100 P.max 360 mbar

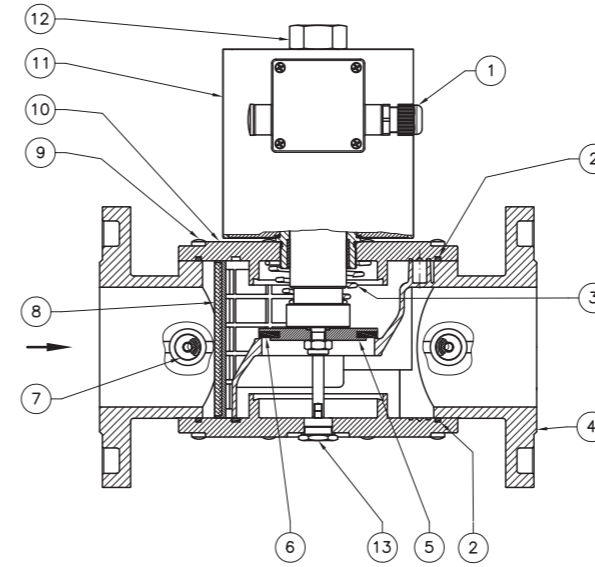
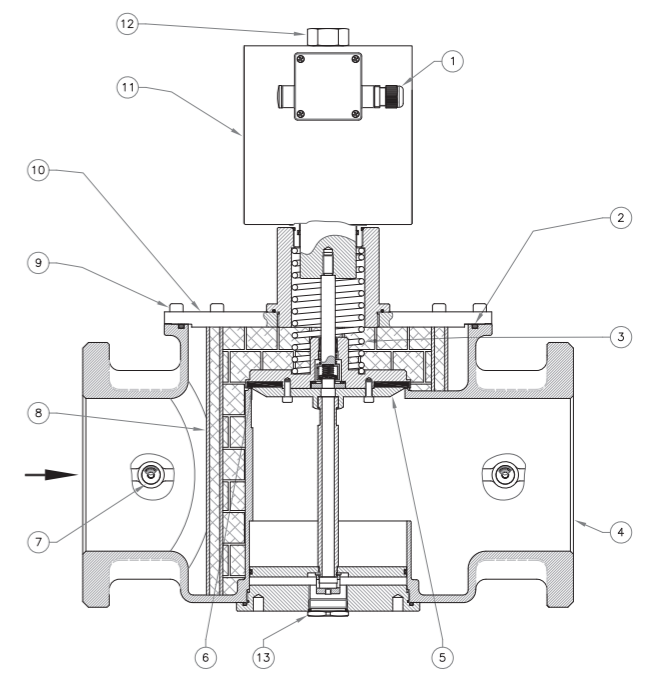

fig. 4 - Abb. 4
DN 125 - DN 150 P.max 360 mbar



CPI Switch installation example

fig. 1, 2, 3, and 4

- | | |
|-------------------------|---------------------------------|
| 1. Electrical connector | 11. Electrical coil |
| 2. Seal O-Ring | 12. Coil fixing nut or screw |
| 3. Closing spring | 13. Cap |
| 4. Body valve | 14. Microswitch |
| 5. Obturator | 15. Aluminium washer |
| 6. Seal washer | 16. Setting ferrule |
| 7. G 1/4" cap | 17. CPI connector |
| 8. Filter | 18. Microswitch fixing nut |
| 9. Fixing screws | 19. Microswitch support ferrule |
| 10. Cover | |

CPI SWITCH

The closed position indicator switch (CPI SWITCH) used for signaling is a magnetic proximity switch with normally open contact. Provides a signal to the closure of obturator of the valve.
If the solenoid valve is supplied with built-in microswitch the sensor position is already setted and fixed, in order to let it work it is sufficient to connect it electrically.
In case it is supplied a part and then installed on a solenoid valve with a predisposition follow the instructions at paragraph "INSTALLATION and CALIBRATION of CPI SWITCH".

CPI SWITCH TECHNICAL DATA

- Environment temperature : -20 ÷ +60 °C
- Switching voltage : max 1000 V (dc or peak ac)
- Switching current : max 1 A (dc or peak ac)
- Switching power : max 40 Watt ohmic
- Resistance : 200 mΩ
- Degree of protection : IP65
- Cable lenght : max 5m

INSTALLATION and CALIBRATION of CPI SWITCH

The gas supply must be shut off before installation.

1. Unscrew the cap (13) under the body valve (4).
2. Screw the microswitch kit (19) instead of the brass cap (13). Check that there is the aluminium washer (15) between body valve (4) and microswitch kit (19).
3. Tight the microswitch kit (19) to the body valve (4) with the proper commercial spanner.
4. Connect the connector terminals 1 and 2 in series to the signaling device. Wire the connector (17) with H05RR-F 2X1 mm² cable outside Ø 6.7 mm, taking care to ensure that the device has IP65 protection.
5. For the microswitch setting, loosen the fixing nut (18) and place (screwing or unscrewing) the setting ferrule (16) to let the micro supply the signal when the solenoid valve is in closed position.
6. Fix the setting ferrule (16) in that position tightening the nut (18).
7. Now the kit is installed. Open and close the solenoid valve (giving and cutting the tension) 2-3 times to check the right signal of the microswitch.

WARNING: the above said operations must be carried out by skilled staff.

fig. 5 - Abb. 5

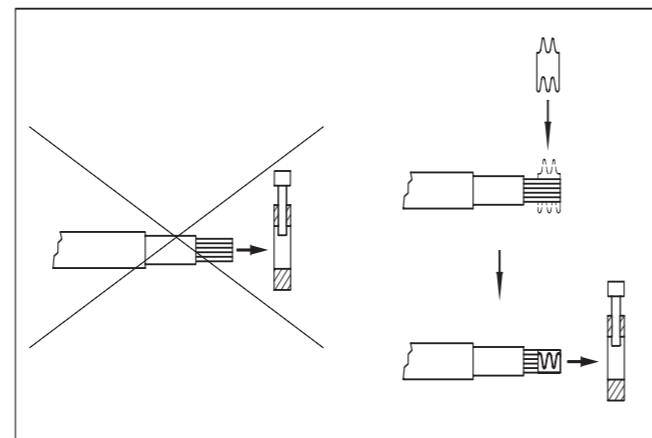

Overall dimensions in mm

Threaded connections	Flanged connections	A	B		C
			without CPI	with CPI	
Rp DN 32	-	160	210	280	165
Rp DN 40	-	160	235	305	165
Rp DN 50	-	160	235	305	165
-	DN 65	290	321	375	211
-	DN 80	310	321	375	211
-	DN 100	350	389	455	254
-	DN 125	480	585	665	328
-	DN 150	480	585	665	328

SIL LEVEL

Parameter	Value
Hardware Failure Tolerance - HFT	0
Common Cause Failure - CCF in points	75
Safe Failure Fraction - SFF in %	65%
Expected Lifetime Cycles - B _{10d}	251278
Expected Lifetime - T _{10d} [hours]	31410
Probability of Dangerous Failures - PFH _D [1/h]	1,33E-07
PL - Performance Level	d
Safety Integrity Level - SIL	2
Mean Time To Dangerous Failure MTTFD ₀ [years]	860

COSTER
COSTER TECNOLOGIE ELETTRONICHE S.p.A.
Head Office: 20132 Milano - Via San G.B. De La Salle, 4/a
Manufactured by: **MADAS s.r.l.**
Via Moratello, 5/6/7 - 37045
Z.A.I. Legnago (VR) Italy

COSTER T.E. UK BRANCH
5 Shaftesbury Street South Tel. +44(0)1332200555
Sir Francis Ley Industrial Park Fax +44(0)1332204181
Derby DE23 8YH
England
E-mail: ukbranch@coster.eu

AUTOMATIC NORMALLY CLOSED SOLENOID VALVE FOR GAS

EVP/NC (GCA/360)

In conformity with Gas Directive 2009/142/EEC, EN 161

II 3G - II 3D